

NB products are available from: MARYLAND METRICS

MARYLAND METRICS

phones: (410)358-3130 (800)638-1830

faxes: (410)358-3142 (800)872-9329

P.O.Box 261 Owings Mills, MD 21117 USA

Internet: <http://mdmetric.com>

E-mail: sales@mdmetric.com

SLIDE SHAFT

SLIDE GUIDE

BALL SPLINE
ROTARY BALL SPLINE

TOPBALL® PRODUCTS

SLIDE BUSH

SLIDE UNIT

STROKE BUSH
SLIDE ROTARY BUSH

SLIDE SHAFT

SLIDE WAY
SLIDE TABLE
GONIO WAY

ACTUATOR

SLIDE SCREW

SLIDE SHAFT

The NB slide shaft is used with bearings such as a slide bush in order to obtain highly accurate linear motion. When used in combination with a slide bush, the shaft performs as the inner race of the bearing system. The quality and accuracy of the shaft directly affect the performance of the slide bush. NB slide shaft is manufactured with an emphasis on quality and accuracy to ensure stable functionality under many operating conditions. Superior performance is guaranteed for both rotational motion and combined rotation and linear motion.

ADVANTAGES

Advanced Machining Technology:

NB will perform a wide variety of highly accurate machining processes to provide custom shafting from relatively simple machining, such as tapping and shaft stepping to the more demanding high-speed rotating shafts and spindles. NB can also perform special grinding and bore machining requirements.

Excellent Wear Resistance:

High wear resistant carbon-chromium bearing steel (SUJ2) and Martensite stainless steel (equivalent to SUS440C) materials are most commonly used. These materials are annealed and tempered to achieve a reliably uniform hardened layer in both the circumferential and axial directions. A cross-sectional photograph illustrating the hardened layer depth of the NB slide shaft is shown below.

Table G-1 Effective Depth of Hardened Layer unit/mm

outer diameter	effective hardened layer depth
over 6mm up to 12mm	0.8 or more
over 12mm up to 30mm	1.0 or more
over 30mm	2.0 or more

※The depth of hardness does not depend on the material used.
hardened layer depth



Surface Roughness:

Precision grinding results in a surface roughness of less than 0.4 Ra.

Wide Selection of Shaft Types:

- SN type
- SNS type
- SNT type
- Tapped shaft type (SNB/SNSB type)
- Fine shaft type (SF/SNSF/SNTF type)
- SNW/SNWS(Inch type)
- SNW-PD/SNWS-PD(Inch type pre-drilled shaft)

Special requirements:

NB will provide slide shafts meeting special requirements (including special shapes and materials) not already covered by the standard product line.



TYPES

SN/SNS Type (NB Shaft)

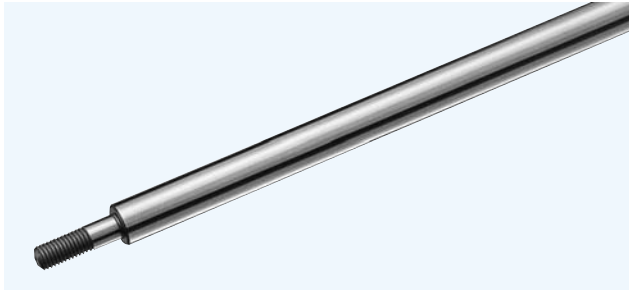

P.G-6

SNT Type (NB Pipe Shaft)

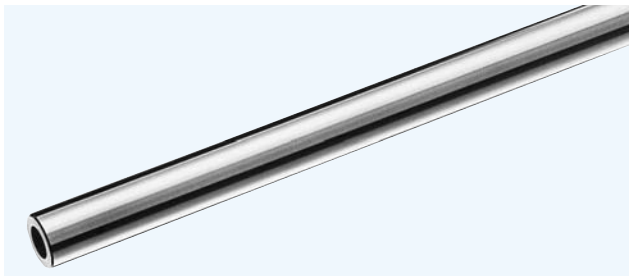

P.G-8

SF/SNSF/SNTF Type (fine shaft)

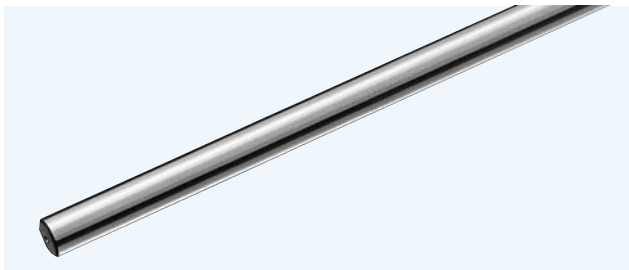

P.G-10

SNW/SNWS Type

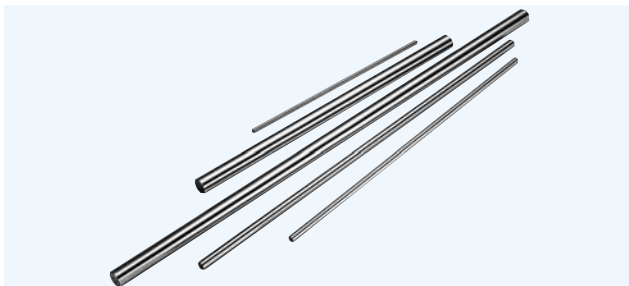

P.G-12

NB's SN/SNS slide shaft is a high-precision, straight, machined shaft series that may be used with a slide bush or as material in other applications.

Table G-2 SN/SNS Specifications

type	SN Type	SNS Type
material	SUJ2	equivalent to SUS440C
outer diameter tolerance	g5 or to be specified	
hardness	60HRC or more	58HRC* or more
surface roughness	less than 0.4Ra	

* For diameters less than 6 mm, HV613 (HRC56) or more.

The SNT pipe shaft may be used to reduce weight without reducing the material's rigidity. It may also be used for channeling electrical wires, hydraulic, or pneumatic sources.

Table G-3 SNT Specifications

type	SNT type
material	SUJ2
outer diameter tolerance	g5 or to be specified
hardness	60 HRC or more
surface roughness	less than 0.4Ra

The SF/SNSF/SNTF fine shaft series are mass-produced straight shaft with the most commonly used dimensions, so it has the benefits of low cost and short lead-time. The tolerance specification of the outer diameter is g6, which is commonly recommended for use with NB's slide bush.

The SNW series are inch dimension shafts with the same level quality as SN/SNS type.

PD (center-lined tapped hole) type is available for relatively long shafts.

PD type can be used with WA shaft support rail (page E-45) for better performance.

SNW/SNWS type

SNW-PD/SNWS-PD type

CALCULATION OF DEFLECTION AND DEFLECTION ANGLE

The following formulas can be used to obtain the deflection and its angle of a linear slide shaft. Some typical conditions are listed in Table G-4.

Table G-4 Formulas for Calculating Deflection and Deflection Angle

#	support method	specification	formula for deflection	formula for deflection angle
1	support - support		$\delta_{max} = \frac{Pl^3}{48EI} = Pl^3C$	$i_1 = 0$ $i_2 = \frac{Pl^2}{16EI} = 3Pl^2C$
2	fixed - fixed		$\delta_{max} = \frac{Pl^3}{192EI} = \frac{1}{4} Pl^3C$	$i_1 = 0$ $i_2 = 0$
3	support - support		$\delta_{max} = \frac{5p\ell^4}{384EI} = \frac{5}{8} p\ell^4C$	$i_2 = \frac{p\ell^3}{24EI} = 2p\ell^3C$
4	fixed - fixed		$\delta_{max} = \frac{p\ell^4}{384EI} = \frac{1}{8} p\ell^4C$	$i_2 = 0$
5	support - support		$\delta_1 = \frac{Pa^3}{6EI} \left(2 + \frac{3b}{a} \right) = 8Pa^3 \left(2 + \frac{3b}{a} \right) C$ $\delta_{max} = \frac{Pa^3}{24EI} \left(\frac{3\ell^2}{a^2} - 4 \right) = 2Pa^3 \left(\frac{3\ell^2}{a^2} - 4 \right) C$	$i_1 = \frac{Pab}{2EI} = 24PabC$ $i_2 = \frac{Pa(a+b)}{2EI} = 24Pa(a+b)C$
6	fixed - fixed		$\delta_1 = \frac{Pa^3}{6EI} \left(2 - \frac{3a}{\ell} \right) = 8Pa^3 \left(2 - \frac{3a}{\ell} \right) C$ $\delta_{max} = \frac{Pa^3}{24EI} \left(2 + \frac{3b}{a} \right) = 2Pa^3 \left(2 + \frac{3b}{a} \right) C$	$i_1 = \frac{Pa^2b}{2EI\ell} = \frac{24Pa^2bC}{\ell}$ $i_2 = 0$
7	fixed - fixed		$\delta_{max} = \frac{Pl^3}{3EI} = 16Pl^3C$	$i_1 = \frac{Pl^2}{2EI} = 24Pl^2C$ $i_2 = 0$
8	fixed - fixed		$\delta_{max} = \frac{p\ell^4}{8EI} = 6p\ell^4C$	$i_1 = \frac{p\ell^3}{6EI} = 8p\ell^3C$ $i_2 = 0$
9	support - support		$\delta_{max} = \frac{\sqrt{3}M_0\ell^2}{216EI} = \frac{2\sqrt{3}}{9} M_0\ell^2C$	$i_1 = \frac{M_0\ell}{12EI} = 4M_0\ell C$ $i_2 = \frac{M_0\ell}{24EI} = 2M_0\ell C$
10	fixed - fixed		$\delta_{max} = \frac{M_0\ell^2}{216EI} = \frac{2}{9} M_0\ell^2C$	$i_1 = \frac{M_0\ell}{16EI} = 3M_0\ell C$ $i_2 = 0$

δ : deflection when load is applied(mm) δ_{max} : maximum deflection(mm) i_1 : deflection angle when load is applied(rad) i_2 : deflection angle at the support(rad) M_0 : moment(N·mm) P : concentrated load(N) p : uniformly distributed load(N/mm) a, b : loading point distance ℓ : span(mm) I : geometrical moment of inertia(mm⁴) E : modulus of direct elasticity 2.06×10^5 (N/mm²) C : $1/48EI$ (1/N·mm³)

The Geometrical moment of inertia (I) is obtained using the following formula:

● For solid shaft

● For hollow shaft

$$I = \frac{\pi D^4}{64}$$

$$I = \frac{\pi}{64} (D^4 - d^4)$$

I : geometrical moment of inertia (mm⁴) D : outer dia. (mm)
 d : inner dia. (mm)

The values of the geometrical moment of inertia and C (=1/48 I) for NB slide shafts are listed in Table G-5 and G-6.

Calculation Examples:

1. Calculate the maximum deformation of a shaft with an outer diameter of 30 mm and a span of 500 mm when a concentrated load of 980 N is applied at the mid-point of the shaft (neglecting the weight of the shaft).

① support-support :

From the given conditions, P is 980 N and ℓ is 500 mm

From Table G-5, C for an outer diameter of 30 mm is 2.54×10^{-12} (1/N mm²).

Substituting these values into the corresponding formula in Table G-4,

$$\delta \max = P \ell^3 C = 0.31 \text{ mm.}$$

② fixed-fixed :

Substituting the values into the corresponding formula given in Table G-4,

$$\delta \max = \frac{1}{4} P \ell^3 C = 0.08 \text{ (mm)}$$

2. Calculate the maximum deformation of a shaft with an outer diameter of 60 mm, an inner diameter of 32 mm, and a span of 2000 mm due to its own weight.

From Table G-6, C for an outer diameter of 60 mm is

$$C = 1.73 \times 10^{-13} \text{ (1/N mm}^2\text{)}$$

The mass per unit length of a shaft with an outer diameter of 60 mm and an inner diameter of 32 mm is 15.9 kg/m. Therefore, a uniformly distributed load of 0.156 N/mm is applied. Substituting these values into the most appropriate formula for your application given in Table G-4.

$$\delta \max = \frac{5}{8} p \ell^4 C = 0.27 \text{ (mm).}$$

Table G-5 Geometrical moment of inertia and C for NB Slide Shafts

outer diameter D(mm)	Geometrical moment of inertia I(mm ⁴)	C=1/48EI (1/Nmm ²)
3	3.98	2.54×10^{-8}
4	1.26×10	8.03×10^{-9}
5	3.07×10	3.29×10^{-9}
6	6.36×10	1.59×10^{-9}
8	2.01×10^2	5.03×10^{-10}
10	4.91×10^2	2.06×10^{-10}
12	1.02×10^3	9.91×10^{-11}
13	1.40×10^3	7.22×10^{-11}
15	2.49×10^3	4.06×10^{-11}
16	3.22×10^3	3.14×10^{-11}
20	7.85×10^3	1.29×10^{-11}
25	1.92×10^4	5.27×10^{-12}
30	3.98×10^4	2.54×10^{-12}
35	7.37×10^4	1.37×10^{-12}
40	1.26×10^5	8.03×10^{-13}
50	3.07×10^5	3.29×10^{-13}
60	6.36×10^5	1.59×10^{-13}
80	2.01×10^6	5.03×10^{-14}
100	4.91×10^6	2.06×10^{-14}
120	1.02×10^7	9.91×10^{-15}
150	2.49×10^7	4.06×10^{-15}

Table G-6 Geometrical moment of inertia and C for NB Pipe Shafts

outer diameter D(mm)	inner diameter d(mm)	Geometrical moment of inertia I(mm ⁴)	C=1/48EI (1/Nmm ²)
6	2	6.28×10	1.61×10^{-9}
8	3	1.97×10^2	5.13×10^{-10}
10	4	4.78×10^2	2.11×10^{-10}
12	5	9.87×10^2	1.02×10^{-10}
13	6	1.34×10^3	7.55×10^{-11}
16	8	3.02×10^3	3.36×10^{-11}
20	10	7.36×10^3	1.37×10^{-11}
25	15	1.67×10^4	6.06×10^{-12}
30	16	3.65×10^4	2.77×10^{-12}
35	19	6.73×10^4	1.50×10^{-12}
40	20	1.18×10^5	8.57×10^{-13}
50	26	2.84×10^5	3.56×10^{-13}
60	32	5.85×10^5	1.73×10^{-13}
80	48	1.75×10^6	5.78×10^{-14}
100	60	4.27×10^6	2.37×10^{-14}

THERMAL-SPRAYING CERAMIC-COATING SPECIFICATION

ADVANTAGES:

Parts that require wear and corrosion resistance may be thermal-sprayed with a ceramic material per NB's ceramic-coating specifications. Material so treated may be used in a wide variety of applications. The pores in the coated layer result in good lubrication characteristics and can be sealed to achieve high corrosion resistance.

APPLICATION EXAMPLES:

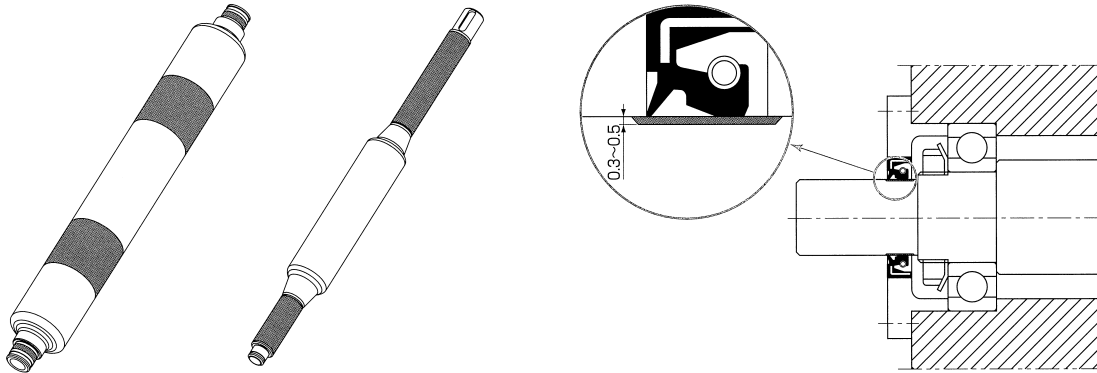

Application of a ceramic coating to oil-sealing parts, rollers, and shafts results in good lubrication and high wear/corrosion resistance characteristics.

Note: Ceramic coated surface cannot be used as the inner race for a slide bush.

REFERENCE:

Standard Coated Materials

High-carbon chromium bearing steel (SUJ2)	Martensite stainless steel (equivalent to SUS440C)
Chrome molybdenum steel (SCM415, 435)	Austenite stainless steel (SUS303, 304)
Carbon steel for machinery (S45C)	Steel alloy for tools (SKS3, SK4)

Proper heat treatment is done on your request. Thermal-spraying ceramic-coating is also available to be applied to other materials.

Standard Ceramic for Melt-Spray

main component	specific gravity	hardness	characteristics
TiO ₂ titanium dioxide	4.7	60HRC	max. temp. 540°C fine coating color: black wear resistant fine surface finish

thermal-spraying layer thickness : 0.3-0.5mm

Other types of ceramic materials can be thermal-sprayed. Contact NB for more information.

Example of Ceramic Coating

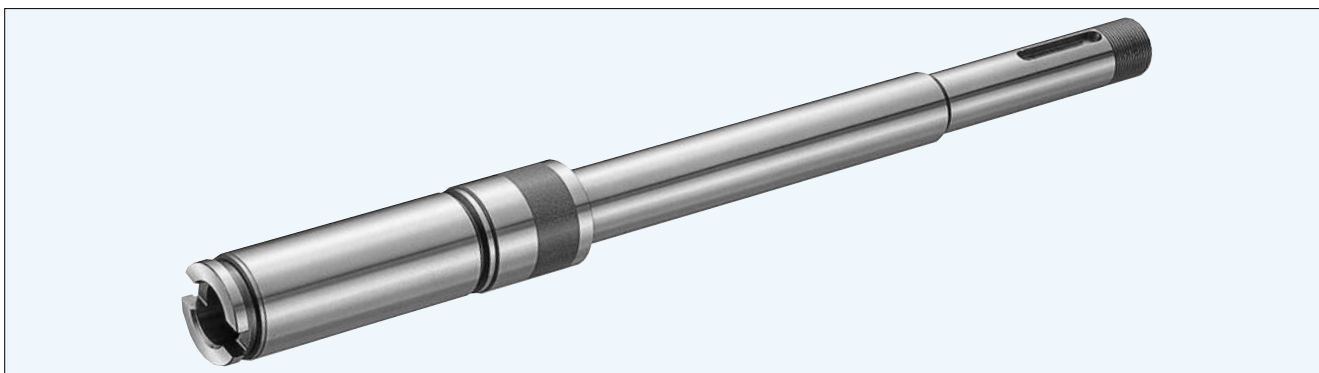

SPECIAL REQUIREMENTS

MACHINING EXAMPLE

NB can fabricate shafts to fit specific customer requirements.

Machining/Grinding:

Shafts can be machined or ground up to a diameter of 400mm and a length of 6000mm.

Internal Surface Grinding:

The straight/tapered portion of the inner spindle can be ground.

Deep Hole Machining:

Non-standard holes can be machined using a gun drill and BT machining methods. (Ref. to Table G-7.)

Screw Machining:

Triangular and trapezoidal screws can be handled.

Compatible Parts:

Special nuts compatible with a given shaft may be machined. The inner surface and outer diameter of the tapered portion can be ground.

Material and Heat Treatment:

Non-NB material and non-NB shape parts can be heat treated. Please specify the heat treatment method and hardness.

Table G-7 Deep Hole Machining Range unit/mm

	hole diameter	maximum length
gun drill machining	φ2~	850(single-side machining)
BT machining	φ30~	2000(single-side machining)

Contact NB for maximum length versus hole diameter information.
 Machining of up to twice the maximum length listed above for double-side machining.

Gun Drill Machining

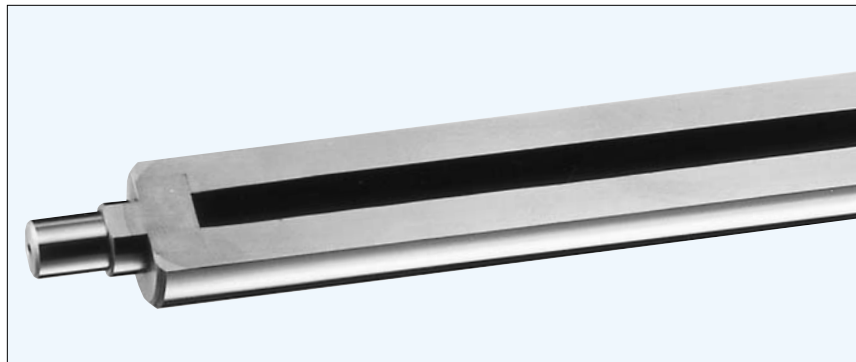
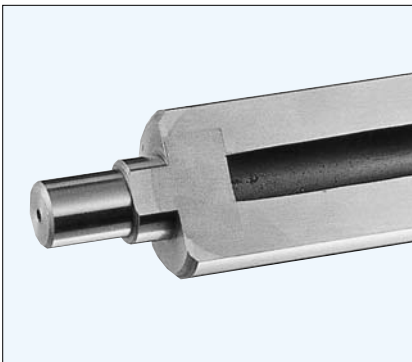

MACHINING EXAMPLES

Roll Shaft

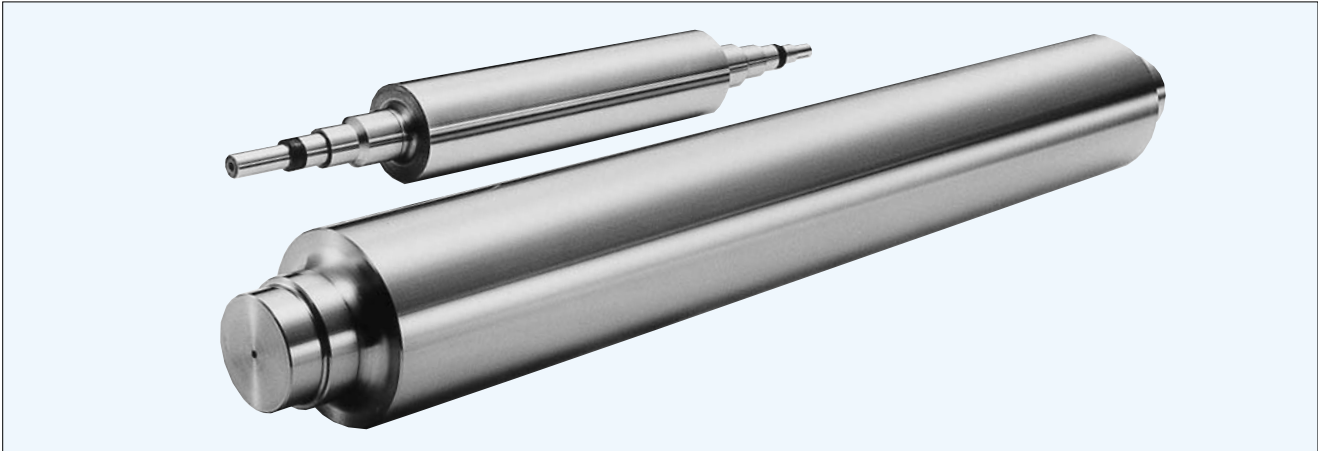

Flanged Shaft

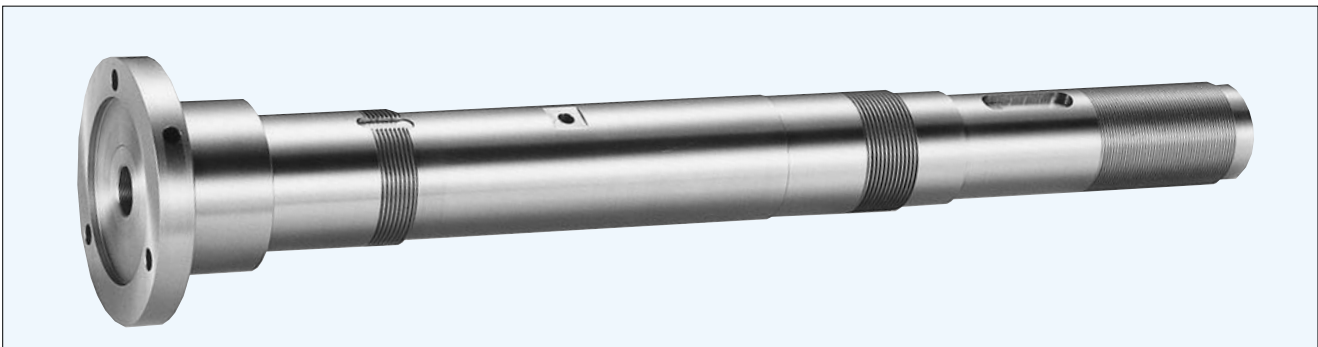
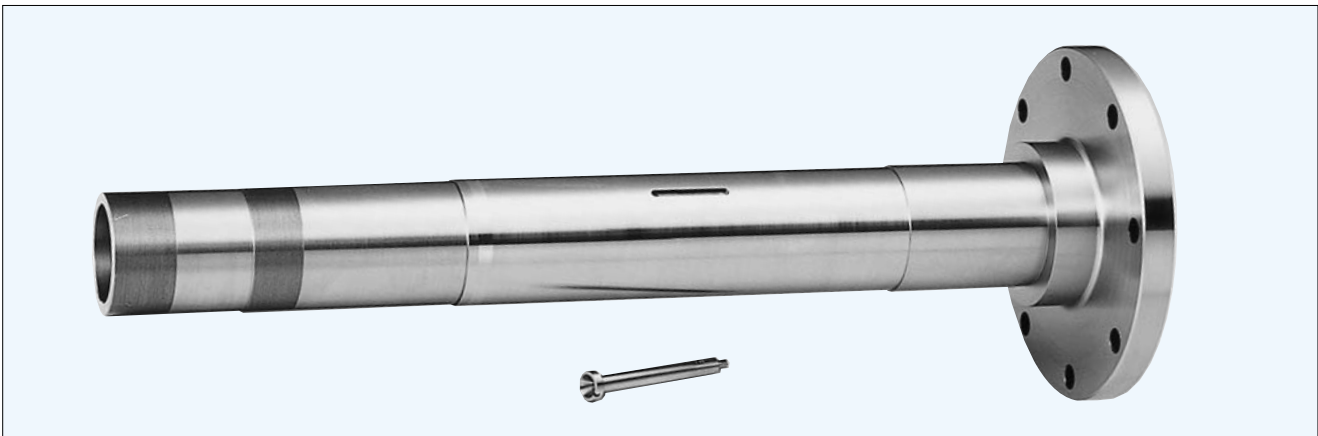

Shaft (spindle)

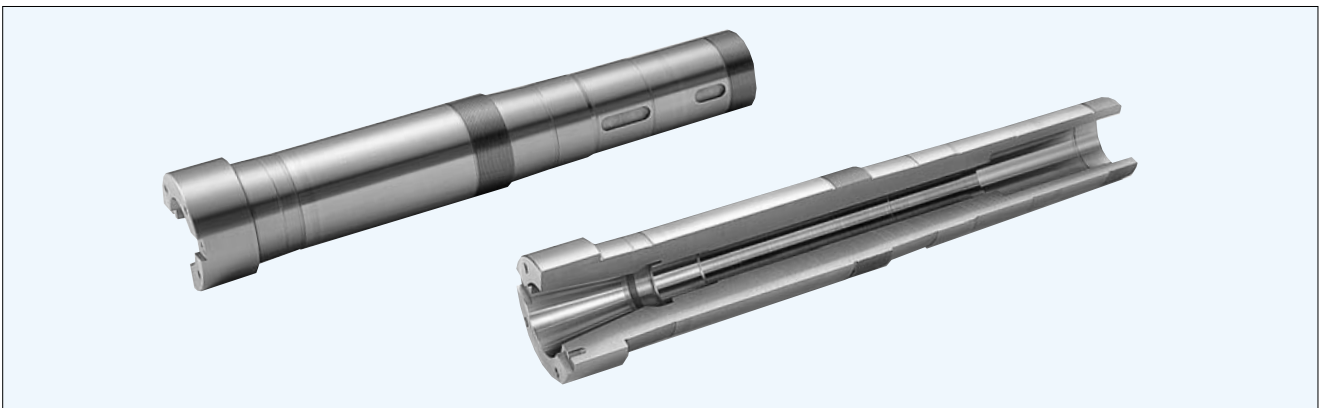
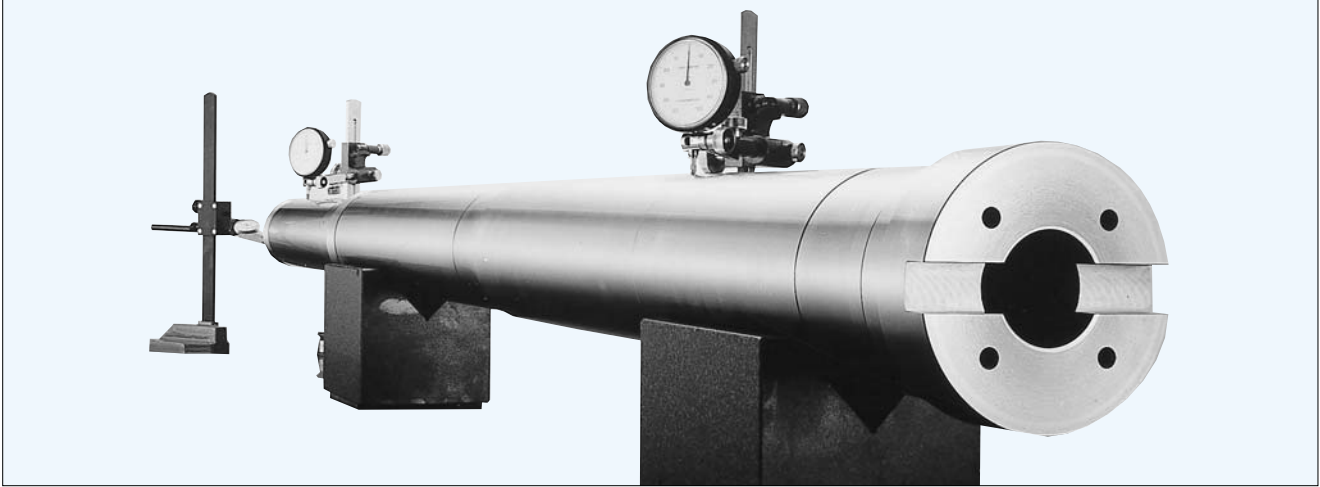

Shaft (Quill)

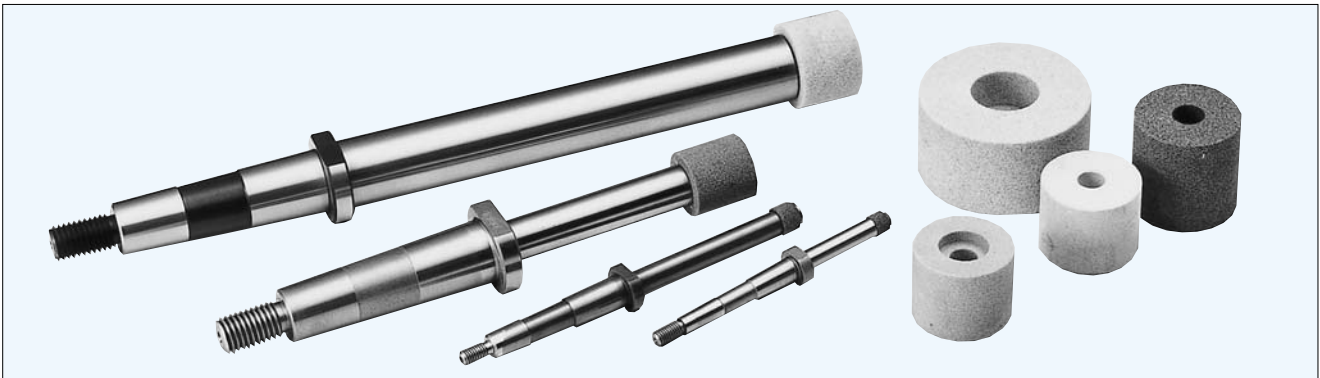

Please send drawing for quotation on custom configurations.

MACHINING EXAMPLES

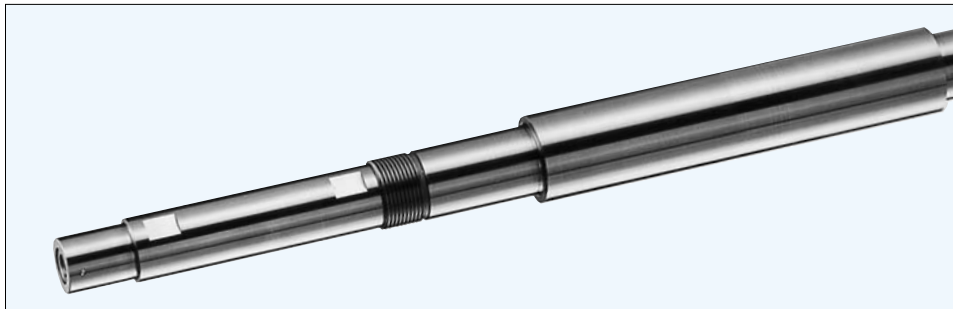
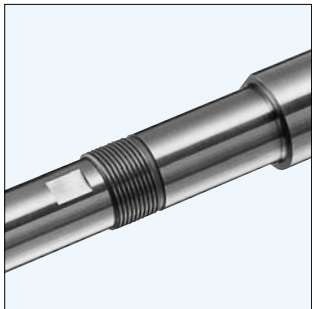
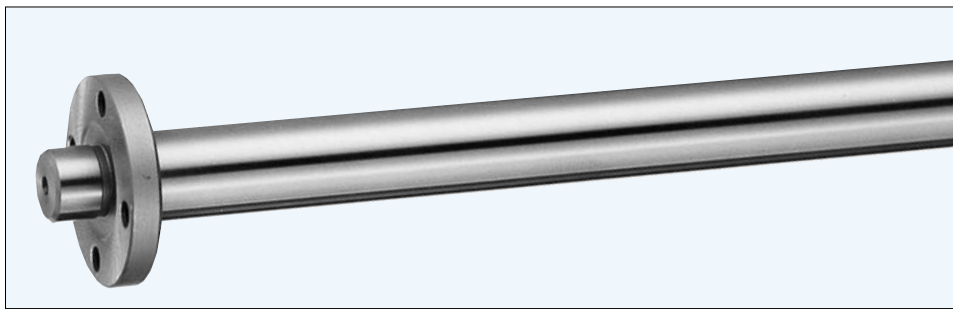
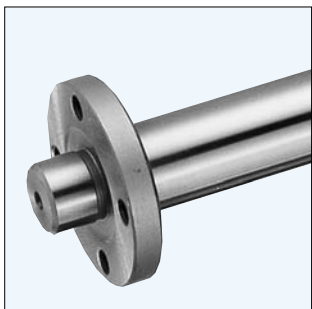
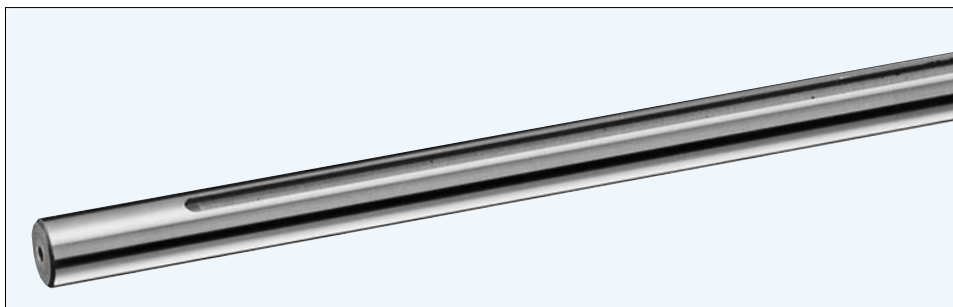
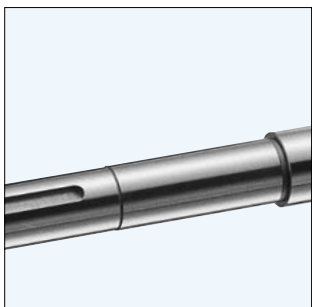
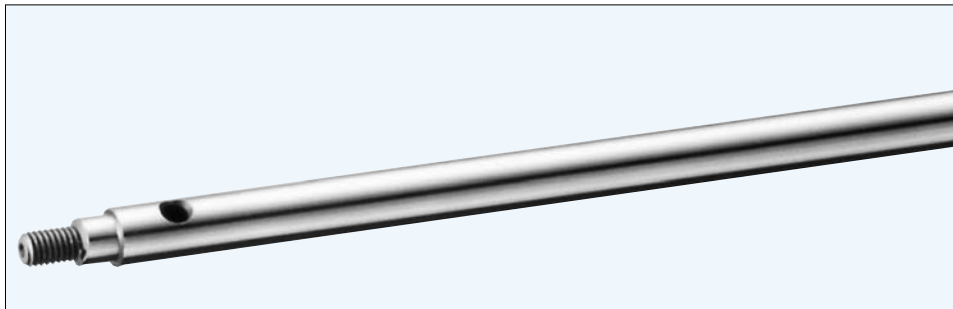
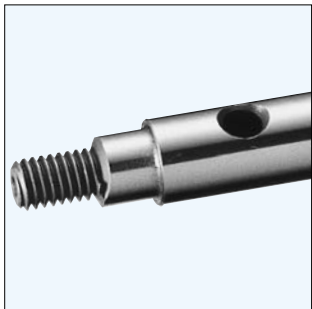

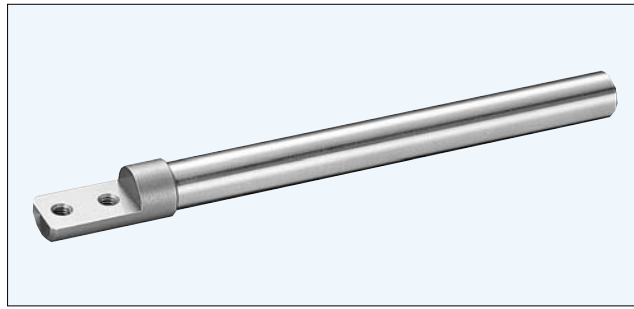
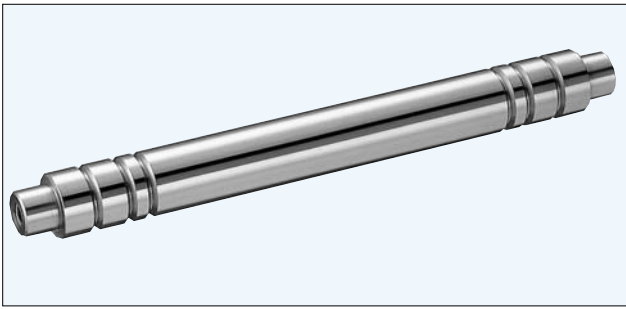
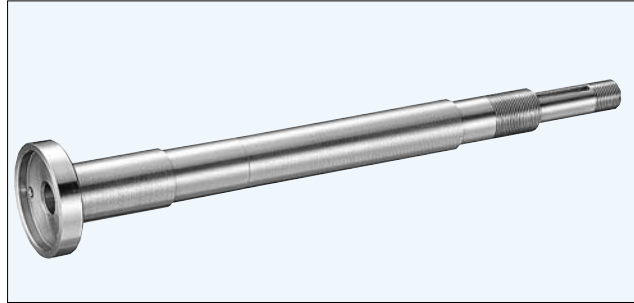
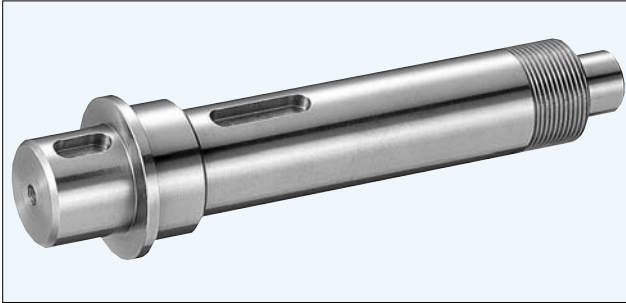

Please send drawing for quotation on custom configurations.